



**WONDER WOMAN TOURBILLON
USER MANUAL**

TABLE OF CONTENTS

WONDER WOMAN TOURBILLON

Overview 3

Movement winding 5

Time setting 6

Buckle opening 7

Buckle release 8

Tech Specs 9

WONDER WOMAN TOURBILLON

FRONT

- 1 Case
- 2 Dial
- 3 Hour hand
- 4 Minute hand
- 5 Tourbillon cage

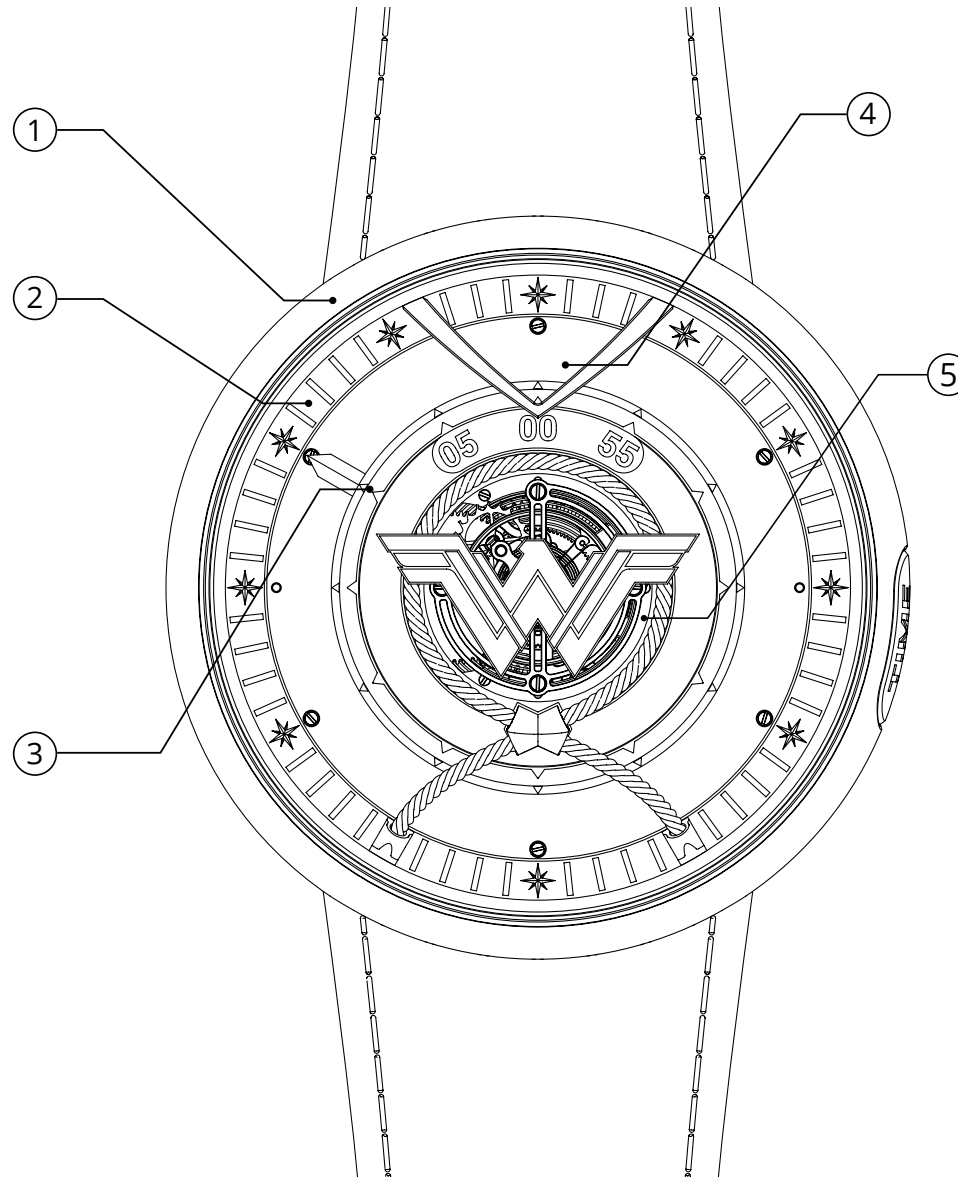

WONDER WOMAN TOURBILLON

BACK

- 6 Time set push button
- 7 D-ring crown
- 8 Strap release push buttons
"Push to release"

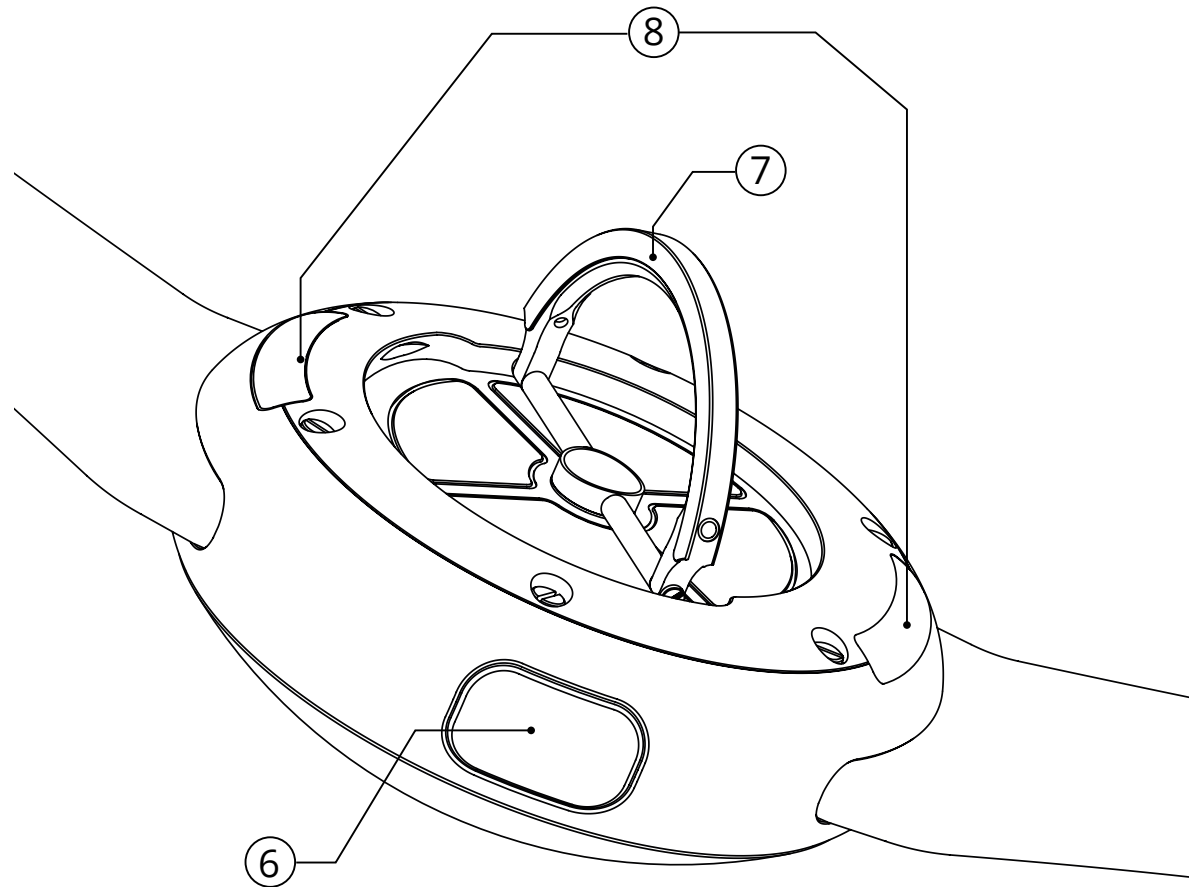

MOVEMENT WINDING

The manual-winding mechanical movement developed in-house delivers a 5 day power reserve. After this period, you must wind your watch to provide the necessary energy for it to run.

In order to maintain perfect symmetry, the "Wonder Woman Tourbillon" case has no traditional crown. On the case back, a D-ring crown is stowed out of sight to help maintain the timepiece's sleek, space-age styling. This mechanism enables faster winding than with a traditional crown.

To wind your watch, lift the D-ring crown and turn it counterclockwise until you feel some resistance, meaning that the watch has been wound.

To fully wind your watch, 23 complete turns are needed.

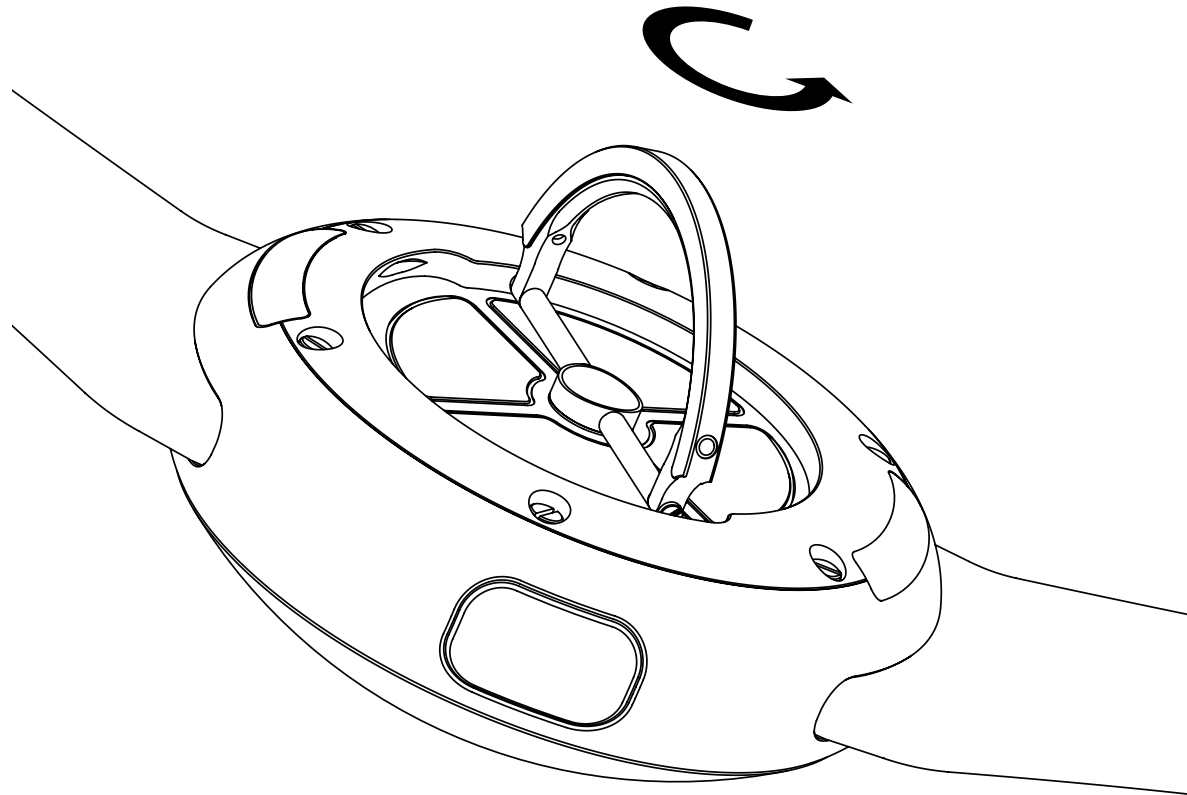

TIME SETTING

The hours and minutes are displayed in a unique peripheral format, made possible by a planetary gear system that orbits 360° around the tourbillon.

To set the time, press the "Time Set" push button. Lift the D-ring crown - located on the case-back - synchronously and turn clockwise until the exact time is set. When setting the time, there may be some resistance as the watch will be wound simultaneously.

Note: You might turn the D-ring crown counterclockwise. In this case, go back 10 minutes before the actual time. Then, turn it clockwise until adjusting the exact time. It enables the gear train to go back to its functioning position.

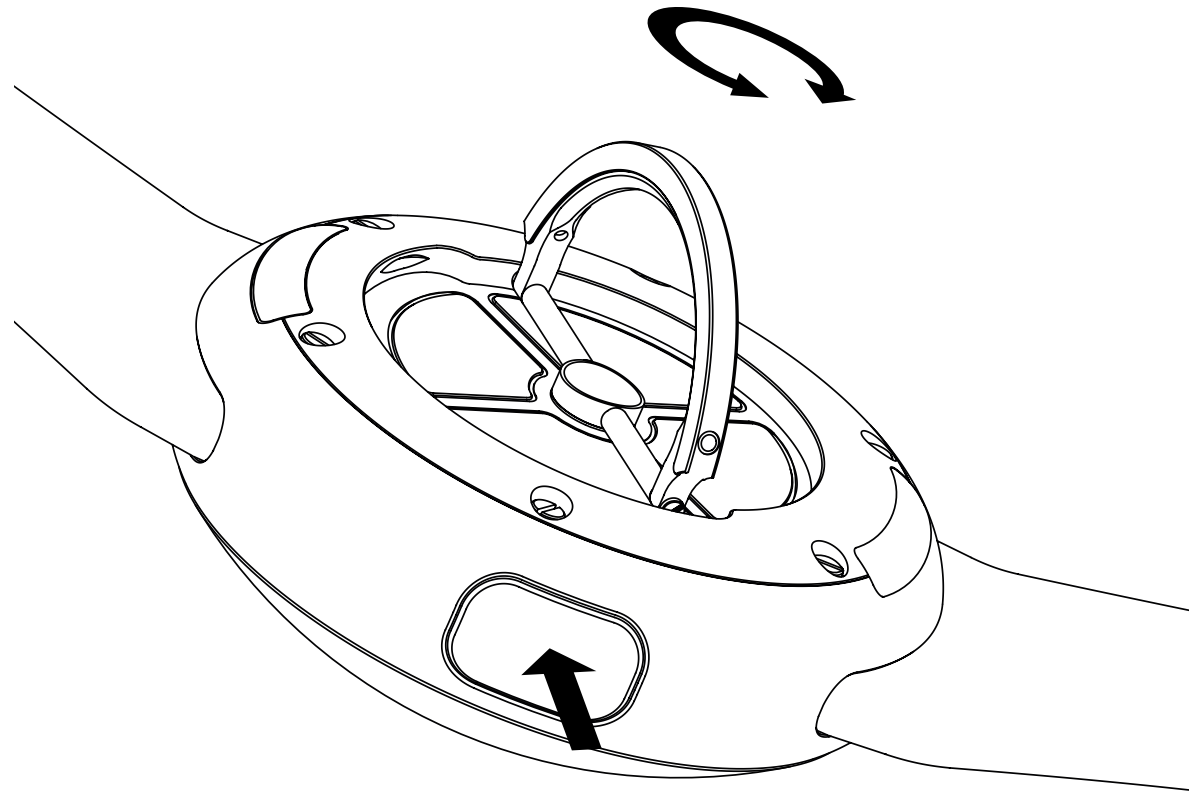

BUCKLE OPENING

Press simultaneously the two push buttons located on the sides of the clasp to open the buckle

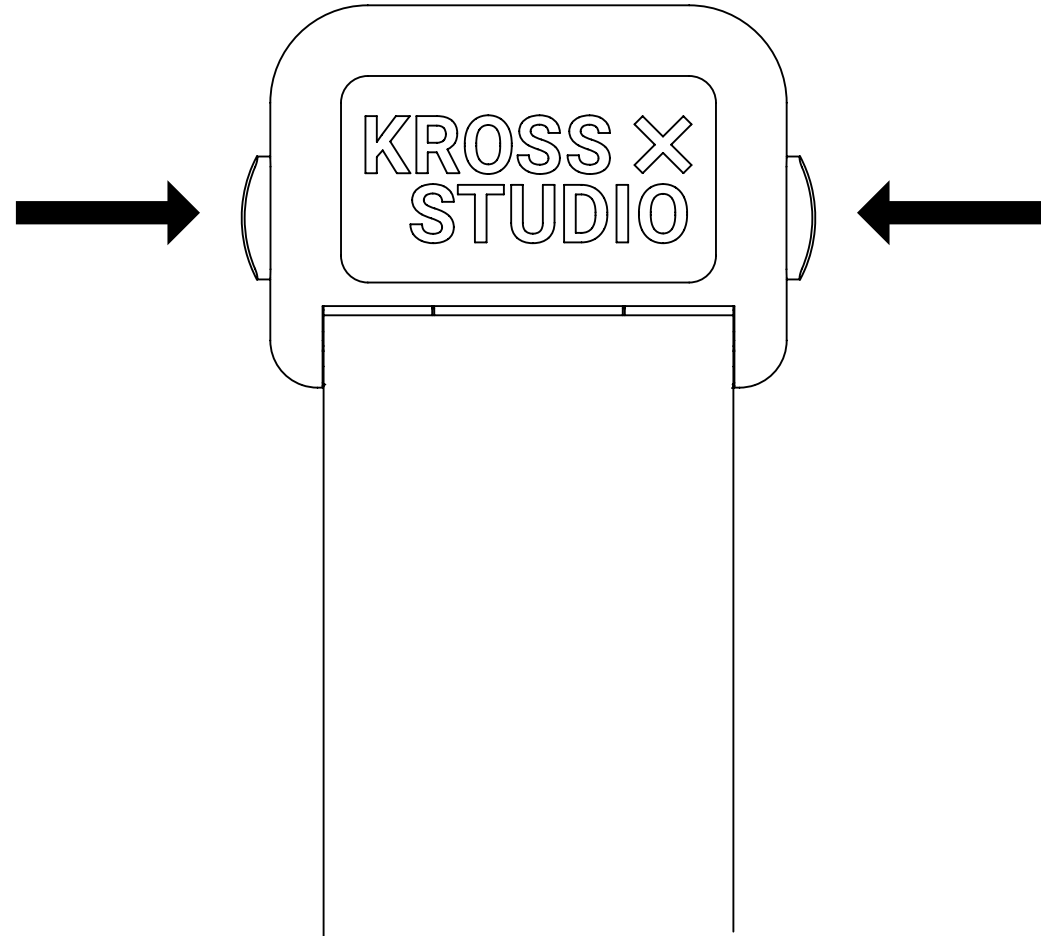

BUCKLE RELEASE

To detach the buckle, no tools are required. Simply pull the lever located under the clasp and it will release the strap.

To fix the buckle, start by inserting the right side of the buckle on the spring bar. Pull the lever and insert the left side.

Make sure the spring bar is securely in place by pulling few times the strap.

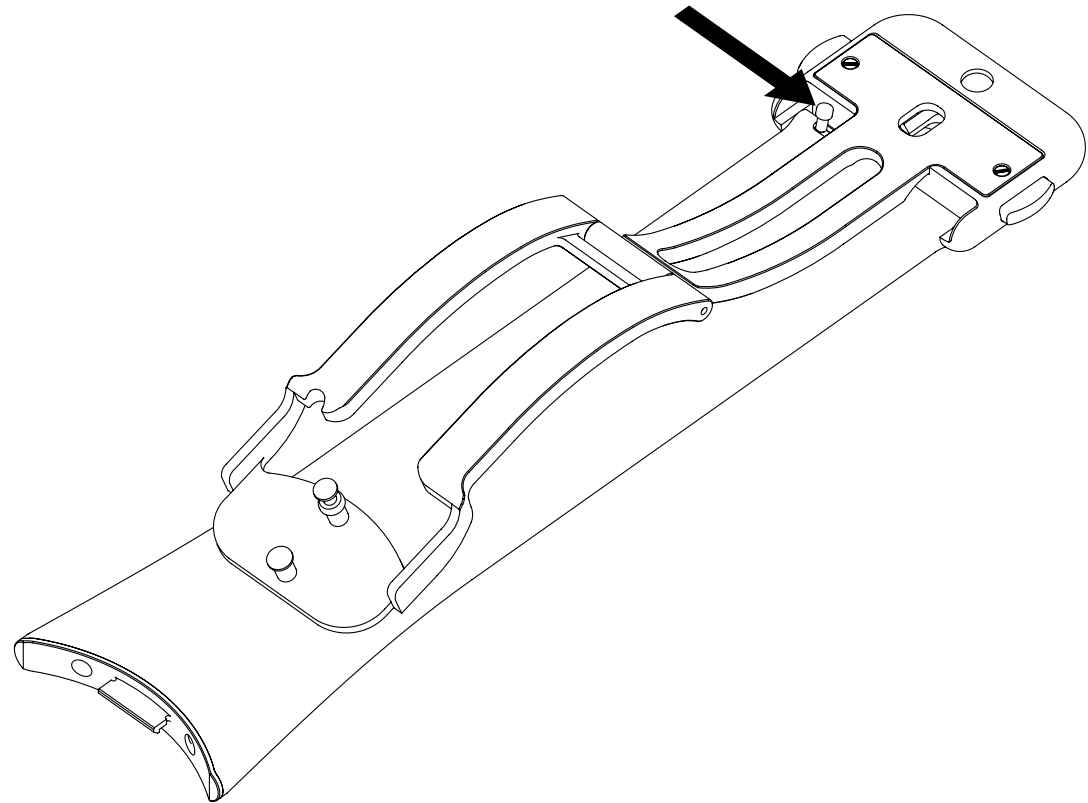

TECH SPECS

WONDER WOMAN TOURBILLON

Parts

283

Limited Edition

Unique Piece

Mouvement

Caliber

KS 7'001

Jewels

27

Fonctions

Manual-winding central tourbillon

Power Reserve

5 days

Parts

205

Frequency

21'600 bph / 3 Hz

Case

Marerials

Grade 5 titanium protected by a black DLC treatment

Diameter

45 mm

Dome-shaped anti-reflective sapphire crystal

Thickness

20 mm

Water resistance

30 mètres ou 3 ATM

Thickness without crystal

12.5 mm

Case back

Materials

Grade 5 titanium

D-ring crown

4 anti-reflective sapphire crystals

INTERCHANGEABLE STRAPS

1. Blue calf leather strap, black stitching

All straps are reinforced with a black rubber inlay for optimal durability and comfort

2. Black rubber strap, black stitching

Black DLC grade 5 titanium clasp
